

07

EXPANDING
BARRIERS

Note: BPG600RW shown with optional locking castors.

When it comes to quality, range and flexibility of design, our Port-a-guard systems leads the industry in expanding barriers. There are models to suit most situations, with a variety of accessories and spare parts to support them.

Typical applications include denying pedestrian access to dangerous or sensitive areas, and closing off aisles when forklifts are operating. Being manufactured from aluminium and high-tech plastics means that all of our Port-a-guard models are suitable for both indoor and outdoor use.

You may also be interested in pages:



50 DOCK-SAFE-Q



89 NEATA



103 SKIPPER



112 CROWD-Q



PORT-A-GUARD EXPANDING BARRIERS

All **NEW** BPG300 and BPG600 model Port-a-guards are not only the best all-round expanding barriers on the market, they now also represent exceptional value.

Now, both models come boxed with all the attachments required for using your barrier in either the **free-standing** or **wall-mounted** configuration.

This means that two separate barriers are now rolled into one. But that's not all: you also receive a **FREE** sign mounting bracket, access to download **FREE** printable signs, and a **FREE** wall receiver bracket that allows your Port-a-guard to be locked to a wall or post when fully extended!

Each boxed barrier also comes with a 12 page user guide. Both new models are available in Red and White or Black and Yellow colour combinations.

NEW VERSATILE 2-in-1 Design

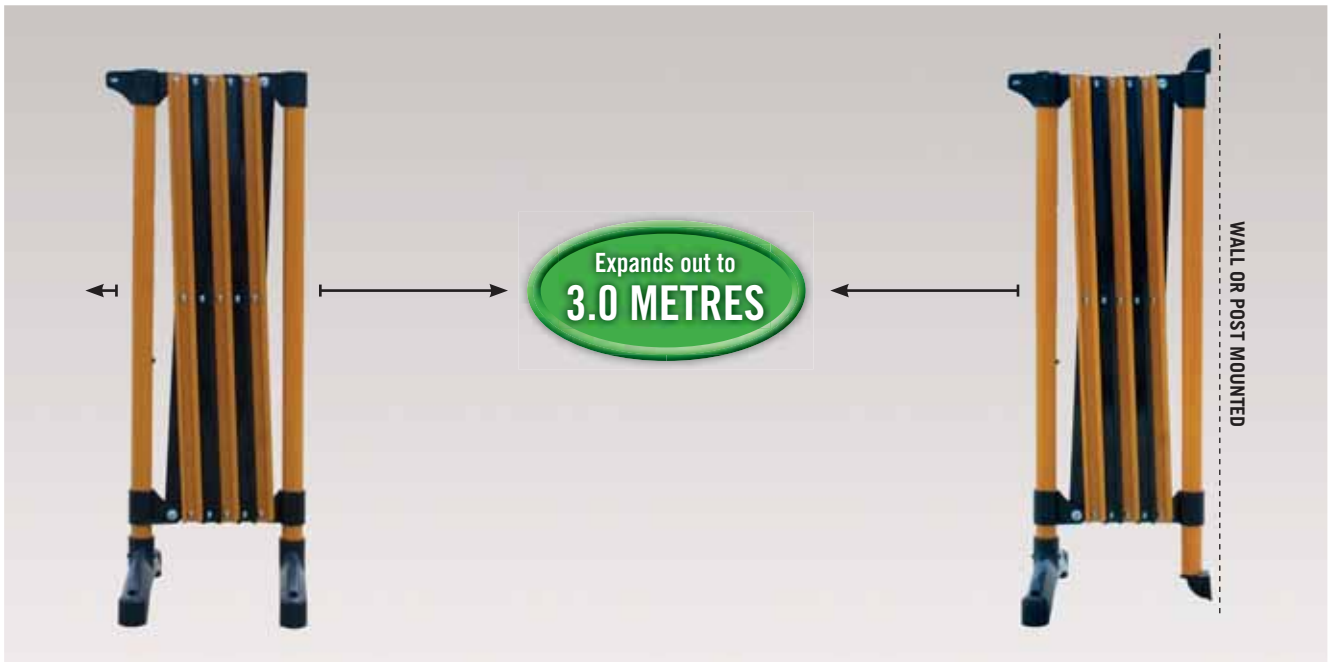

BPG300BY
Shown in freestanding configuration.

BPG300BY
Shown in wall-mounted configuration.



BPG600RW
Shown in freestanding configuration.

BPG600RW
Shown in wall-mounted configuration.

Value features:

- » New exceptional value 2-in-1 design.
- » Lower cost than the models they replace.
- » Wider 400mm feet for increased stability.
- » Supplied with free wall receiver bracket.
- » Aluminium and hi-tech plastic construction.
- » Range of tailored accessories available.
- » Available in two colour combinations.
- » Full range of spare parts available.
- » Available in 3.0 metre and 6.0 metre models.
- » Free printable sign downloads.

Specifications

Description:	Fixed or Portable expanding barrier.
Material:	Posts & slats extruded aluminium. Fittings injection moulded ABS.
Finish:	Powder coated aluminium, black ABS.
Height (open):	With out castors 990mm. With optional locking castors 1090mm.
Width:	BPG300 Extended 3.0 metres/closed 325mm. BPG600 Extended 6.0 metres/closed 625mm.
Weight:	BPG300 (boxed) 5.7kgs. BPG600 (boxed) 9.8kgs.



Wall Receiver Bracket

The wall receiver bracket allows your Port-a-guard to be locked in position to temporarily close off an area, restrict access or prevent unauthorised removal of your expanding barrier.



New Foot Design

The stylish new foot design is injection moulded from durable ABS plastic. For increased stability, it is 65mm wider than the old model.



Spare Parts

In the event your Port-a-guard is damaged, we carry a full range of spare parts, including feet, brackets, slats and all fixings.



Free Sign Downloads

Purchase our optional A4 or A5 sign holder pockets and have FREE access to download and print a range of sign faces. Simply visit www.barsec.com.au.

PART No.	DESCRIPTION
BPG300RW	Port-a-guard expanding barrier 3.0 metre (2-in-1) kit – Red/White
BPG300BY	Port-a-guard expanding barrier 3.0 metre (2-in-1) kit – Black/Yellow
BPG600RW	Port-a-guard expanding barrier 6.0 metre (2-in-1) kit – Red/White
BPG600BY	Port-a-guard expanding barrier 6.0 metre (2-in-1) kit – Black/Yellow
BPG-LC	Optional locking castor (each)
BPG93	Optional 1.5kgs leg weight (each)
BPG-A4SH	Optional A4 sign pocket (each)
BPG-A5SH	Optional A5 sign pocket (each)
BPG29SM	Optional mounting post (each)
BGK4	Below ground kit for mounting post
BPG-WSB	Additional wall/sign mount bracket
BPG-WR2	Additional wall receiver bracket

BPG300 (Red/White or Black/Yellow)

- A. 1 x Port-a-guard 3.0 metre body
- B. 2 x Moulded feet
- C. 3 x Wall/Sign mounting brackets
- D. 1 x Wall receiver bracket

MAX. 3000mm

What you get in the BPG300 series kit.

BPG600 (Red/White or Black/Yellow)

- A. 1 x Port-a-guard 6.0 metre body
- B. 3 x Moulded feet
- C. 3 x Wall/Sign mounting brackets
- D. 1 x Wall receiver bracket

MAX. 6000mm

What you get in the BPG600 series kit.

OTHER MODELS

BPG2 Port-a-guard Flexi

The Port-a-guard Flexi is unlike any other product on the market. Apart from its ability to expand out to 5.4 metres, it also pivots at the middle through a full 270 degrees and can step up to 300mm for changing floor levels.

A full range of spare parts and accessories is readily available for all Port-a-guard models.

Finished in red/white or black/yellow powder coat.

Weight 9.2kgs. Width when closed 300mm. Width when fully extended 2 x 2700mm.

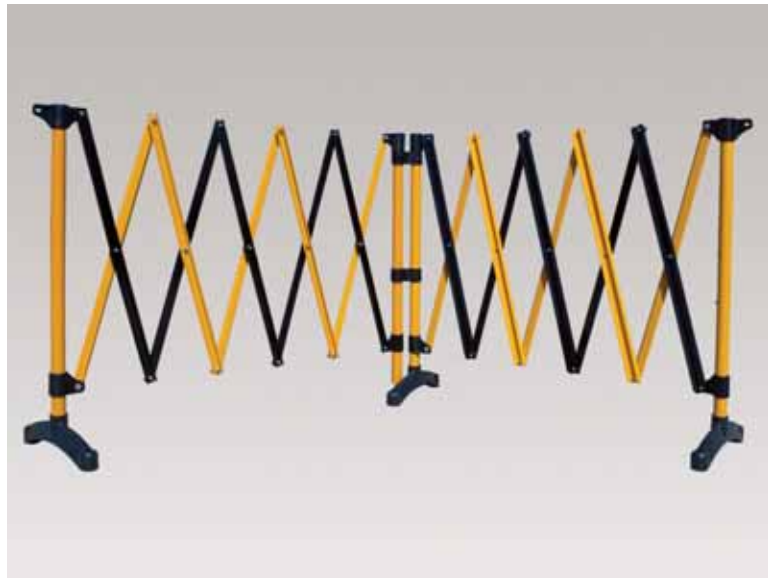

BPG2BY shown.

PART No.	DESCRIPTION
BPG2RW	Port-a-guard flexi expanding barrier 2 x 2.7 metre – Red/White
BPG2BY	Port-a-guard flexi expanding barrier 2 x 2.7 metre – Black/Yellow

BPG6 Port-a-guard Utility

Consisting of three sides – each capable of expanding out to 2.6m – the Port-a-guard Utility has been designed for cordoning off small spaces.

This Port-a-guard is manufactured from non-corrosive powder coated aluminium, and is compact and easily carried by one person.

Spare parts and accessories are readily available for all Port-a-guard models.

Finished in red/white or black/yellow powder coat.

Weight 17kgs. Width when closed 360mm. Width when fully extended 3 x 2600mm.



BPG6RW shown.

PART No.	DESCRIPTION
BPG6RW	Port-a-guard utility expanding barrier 3 x 2.6 metre – Red/White
BPG6BY	Port-a-guard utility expanding barrier 3 x 2.6 metre – Black/Yellow

BPGL8BY Port-a-guard Light

The Port-a-guard Light is a portable, expanding crowd control barrier. Compact and lightweight, the BPGL8BY is suitable for both indoor and outdoor use, and the built-in handle and locking strap simplifies handling and portability.

The plastic slats and legs are corrosion resistant, durable and lightweight. However, if extra stability is required – for example in windy conditions – the legs can be filled with water, adding weight.

This Port-a-guard is truly a versatile and portable solution to your pedestrian traffic control problems.

Finished in black/yellow plastic. Weight 3kgs.

Closed 250mm. Open 2400mm at 970mm high.



BPGL8BY shown.

PART No.	DESCRIPTION
BPGL8BY	Port-a-guard light expanding barrier 2.4 metre – Black/Yellow

PORT-A-GUARD ACCESSORIES



Locking Castors

Port-a-guard locking castors quickly and cost effectively convert your new or existing Port-a-guard, making it much easier to move about. Locking castors are sold individually. No special tools or modifications are necessary; simply attach the castors with the fixings provided. Two models available: BPG-LC for fixing to plastic feet and BPG-LPC for fixing to single posts.

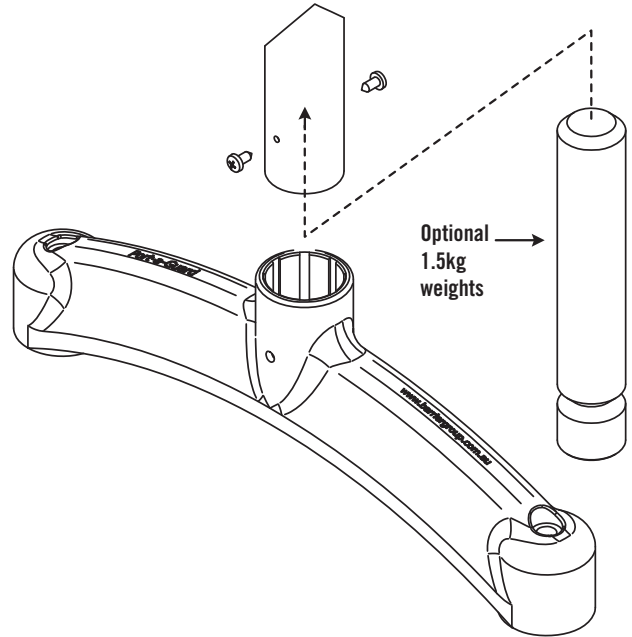

Post Weights

BPG93

Our optional base weights add 1.5kgs per post and are ideal for high-wind areas. Weights are sold individually.

To install, simply remove the foot from the post, insert the weight into the post and re-fit the foot. Weights are held in position by the foot retaining screws.

Mild steel with a zinc plated finish.

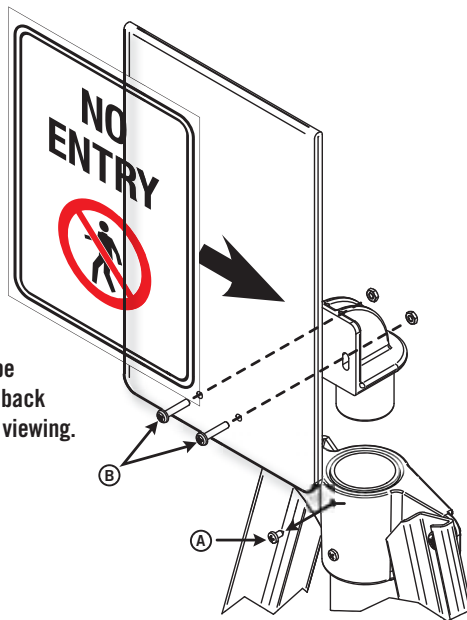

Note: Signs can be inserted back to back for double-sided viewing.

Sign Pockets

BPG-A5SH / BPG-A4SH

Our new acrylic sign pockets forever eliminate the need to purchase expensive signs. Available to suit either A4 or A5 paper sizes, they are attached to the Port-a-guard using the bracket supplied with both BPG300 and BPG600 models.

Additional sign brackets can be purchased. Simply make your own signs or visit www.barsec.com.au for a range of free sign faces to download and print on any office printer.



Mounting Posts

BPG29SM

A freestanding post for installation of fixed Port-a-guards where there is not a wall or structure to mount off. Simply mount your Port-a-guard using the brackets supplied. The post is a steel structure with a base flange. It has a black powder coated finish. If mounting into a new concrete footing, use with BGK4 in-ground kit.

PORT-A-GUARD MAXI

With a standard opening of 6.7 metres, the Maxi takes the Port-a-guard range to a new level of versatility.

With an increased height, reduced gap between the floor and the bottom of the barrier and smaller opening size between the slats, the Maxi offers an even greater level of security and safety.

A combination of aluminium slats, galvanised slide components and stainless steel fixings means the Maxi is suited to both indoor and outdoor applications. The Maxi now has four locking castors as standard.

Value features:

- » Complete with four heavy duty locking castors.
- » Non-corrosive construction for outdoor use.
- » Increased safety and security due to reduced opening sizes.
- » Can be linked together to form a continuous barrier.
- » Easily transported by one person.

Specifications

Description:	Portable expanding barrier.
Material:	Slats & posts – extruded aluminium. Slide guides – Hot dipped galvanised steel. Assembly fittings – Stainless steel.
Finish:	Natural aluminium.
Height (open):	1430 mm from ground to top of slats.
Width:	Open 6.7 metres / Closed 580mm.
Weight:	32.2kgs.

PART No.	DESCRIPTION
BPGM140	Port-a-guard maxi expanding barrier 1430mm x 6.7 metre
BPG-WR	Wall receiver bracket
BPGM-MC	Replacement middle castor assembly
BPGM-RF	Replacement foot with 2 castors



Port-a-guard Maxi comes standard with 4 heavy duty locking swivel castors and central fixed dolly wheels for ease of movement from one location to another.

Alternatively, Maxi can be wall mounted at one end using the optional wall receiver bracket and rolled out as required with minimal effort.

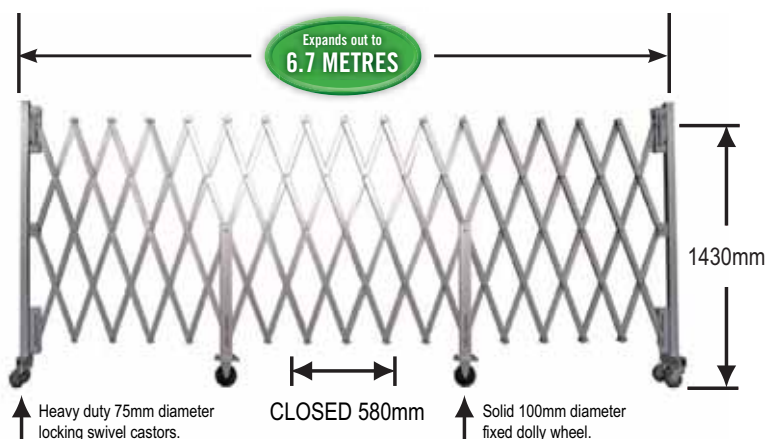

CLOSED: Port-a-guard Maxi.

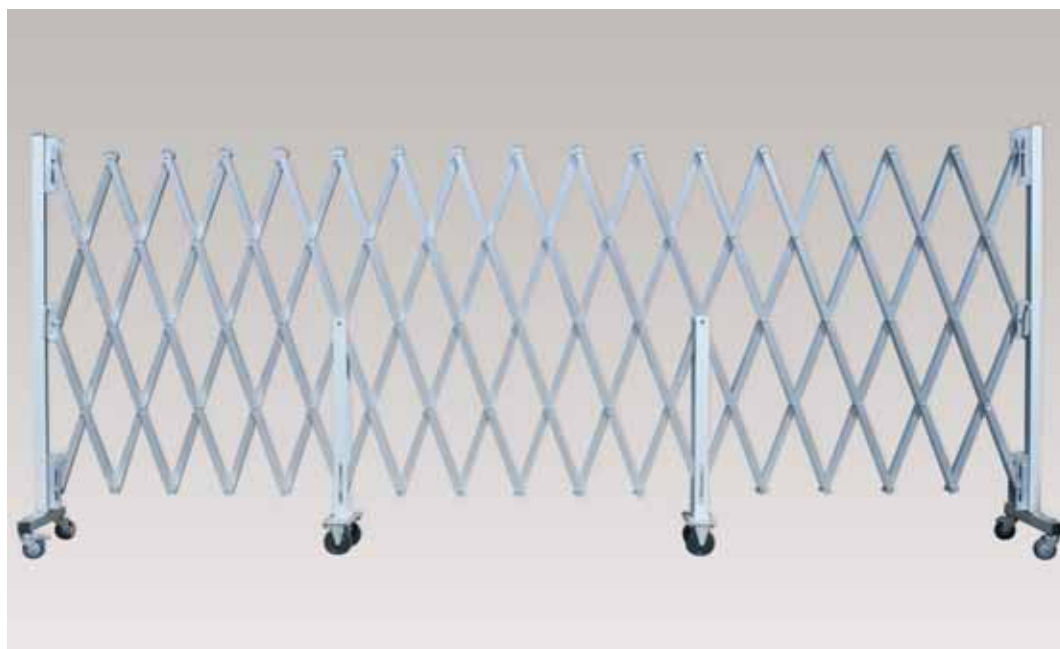

OPEN: Port-a-guard Maxi.