



ECONOMY RUBBER SPEED HUMP

This speed hump is an economical alternative to more expensive models. It is ideally suited to lower traffic environments such as unit and town house developments or for short term installations. They are manufactured from a mixture of natural and recycled rubber. When laid in an alternating pattern they conform to AS/NZS 2890.1:2004. Can also be used as a liquid bunding if installed with a sealant such as silastic.

Features:

- Designed to comply with AS/NZS 2890.1:2004.
- Can be used with or without end caps.
- Comes complete with all fixings.
- Concealed fixings remain accessible.
- Built in bridge design to accommodate a cable or hose (when used without end caps).

Material:	Recycled and natural rubber.
Finish:	Black or Yellow body modules. Black end caps.
Length:	250mm body module (i.e. 4 per metre). 190mm radius end cap.
Width:	350mm.
Height:	52mm.
Ramp angle:	2:1.
Weight:	4kgs body module. 2kgs end cap.
Fixings:	2 per body module (supplied). 4 per pair end caps (supplied).

PART No.	DESCRIPTION
SME50Y	Economy rubber speed hump 250mm body – Yellow
SME50B	Economy rubber speed hump 250mm body – Black
SMEC	Economy rubber speed hump end caps (1 pair) – Black
BSHKIT	Complete speed hump sign kit

Economical and quiet,
ideal for use around
residential areas

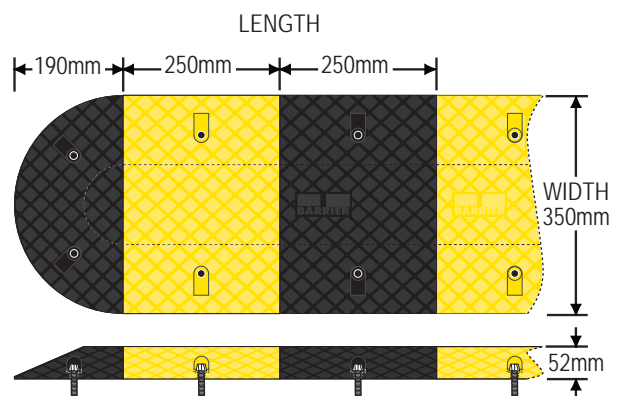
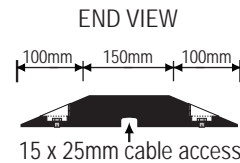



ROUND RUBBER HUMPS

Features:

- Full load bearing contact area with road surface.
- Convenient modular system can be configured to any length.
- All modules supplied with fixings.
- Concealed fixings remain accessible.
- Shock absorbent rubber is quiet and smooth.
- Rubber construction conforms to uneven surfaces.



Material:	Solid natural and recycled rubber.
Finish:	Black/Yellow moulded rubber sections.
Length:	500mm body modules. 250mm end caps.
Width:	350mm (body modules and end caps).
Height:	50mm.
Weight:	7kgs body module (each). 2kgs end caps (pair).
Fixings:	4 per body module. 2 per pair or end caps (supplied).

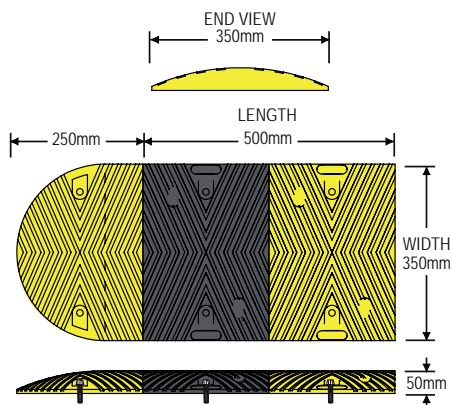

PART No.	DESCRIPTION
SMTC350BY	Round rubber hump body 350 x 500 x 50mm – Black/Yellow
SMTC350EB	Round rubber hump end cap 350 x 250 x 50mm – Black
SMTC350EY	Round rubber hump end cap 350 x 250 x 50mm – Yellow
BSHKIT	Complete speed hump sign kit



ROAD SPIKES One Way Access Spikes

Features:

- Extremely strong construction, 6mm top plate.
- Hi-Vis Lime Green with Orange spikes.
- Deters access from unauthorised direction.
- All teeth operate independently of each other.
- Low profile design ensures legal vehicle clearance.
- Soft approach due to low ramp angle.
- Comes complete with all fixings.
- Available in 1000 and 500mm lengths.
- Non-locking designed spikes.

Finish:	Powder coated Lime Green and Orange.
Top Skin:	6mm floor plate.
Length:	1000mm or 500mm.
Width:	380mm.
Height:	95mm teeth extended. 50mm teeth retracted.
Weight:	BRS500 – 13kgs (approx.) BRS1000 – 26kgs (approx.) BRSE – 5kgs per pair (approx.)
Fixings:	8 per metre (supplied). 4 per ½ metre (supplied).



PART No.	DESCRIPTION
BRS1000	Blade runner one way access spikes body – 1000mm
BRS500	Blade runner one way access spikes body – 500mm
BRSE	Blade runner end caps (pair)
BRSKIT	Blade runner warning sign kit