



STEEL SPEED HUMP

Slo-Motion Standard Duty

Features:

- Designed to comply with AS/NZS 2890.1:2004.
- More than four times the load bearing contact area with the road surface than competitor's products.
- Can be used with or without rubber end caps.
- Comes complete with all fixings.
- Truly independent modules for easy removal.
- **Does not need a rubber underlay to prevent rattle.**
- Concealed fixings remain accessible.
- Modules have a built in bridge design to accommodate hoses or cables.

Top skin:	3mm floor plate.
Length:	1 metre or 1/2 metre.
Width:	350mm.
Height:	52mm.
Ramp angle:	2:1.
Weight:	SM1000 – 16.5kgs. SM500 – 9.2kgs. SMEC – 5.2kgs/pair (rubber).
Fixings:	4 x masonry anchors (supplied).

**Ideal for car parks,
shopping centres or
factory complexes**

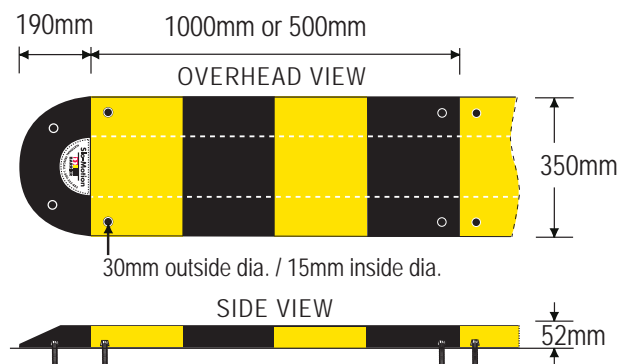
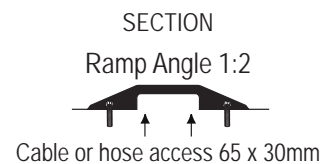

PART No.	DESCRIPTION
SM1000	Slo-Motion standard duty steel speed hump – 1 metre
SM500	Slo-Motion standard duty steel speed hump – 0.5 metre
SMEC	Rubber end caps – 1 pair
BSHKIT	Complete speed hump sign kit
SPIKES	Optional steel gravel spikes for fixing into loose surfaces – 300 x 12mm each

