



COMPLIANCE WHEEL STOP

Features:

- Complies to AS/NZS 2890.1:2004.
- Solid colour and U.V. stabilised environmentally friendly Linear Low Density Polyethylene (LLDPE).
- Extremely tough structure with retained flexibility.
- Lightweight, at only 5.5kgs, it is easy for one person to install.
- Four high-strength fixing points with blanking plugs to provide a flush finish and conceal fixings.
- Available in three colours – Yellow, Disabled Blue and Grey.
- Three standard fixing systems available for installing onto concrete, bitumen or asphalt.
- Moulded-in sign recess for personal identification.
- Optional reflector plugs and parking signs available.
- Absolutely unique, world-first design.
- Comes complete with fixings and blanking plugs.

Material:	Injection moulded Linear Low Density Polyethylene (LLDPE).
Finish:	Solid colour in Yellow, Blue or Grey.
Length:	1700mm to AS/NZS 2890.1:2004.
Width:	160mm at the base.
Height:	100mm to AS/NZS 2890.1:2004.
Weight:	5.5kgs each (approx.)
Fixings:	Three kit options in the part numbers table.



RMIT University proves Barrier Group's Compliance Wheel Stop is better for the environment than recycled rubber

Definitive conclusions from RMIT University indicated that the Compliance Wheel Stop is a better alternative than recycled rubber, for five different measures of environmental impact.

PART No.	COMPLIANCE WHEEL STOPS
CWS1700Y	Compliance wheel stop – Yellow (fixings supplied).
CWS1700B	Compliance wheel stop – Disabled Blue (fixings supplied).
CWS1700G	Compliance wheel stop – Concrete Grey (fixings supplied).
KIT17	Use for fixing into good quality asphalt or bitumen.
KIT18	Use in conventional reinforced concrete. Drill depth 85mm.
KIT19	Use for shallow drilling into concrete. Drill depth 43mm.
BMR	Optional reflector plugs (each)
PART No.	WHEEL STOP SIGNS
CWS-VISITOR	Wheel stop sign 75 x 450mm – VISITOR (Black text)
CWS-DISABLED	Wheel stop sign 75 x 450mm – DISABLED (Blue text)
CWS-STAFF	Wheel stop sign 75 x 450mm – STAFF (Black text)
CWS-15MIN	Wheel stop sign 75 x 450mm – 15 MINUTE (Black text)
CWS-RESERVED	Wheel stop sign 75 x 450mm – RESERVED (Black text)
CWS-BLANK	Wheel stop sign 75 x 450mm – BLANK

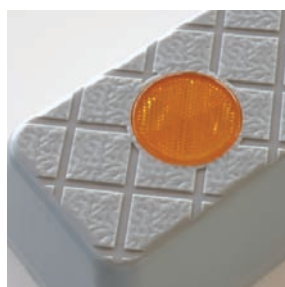



RUBBER WHEEL STOP

An economical one piece rubber wheel stop with Hi-Vis Yellow panels. Manufactured from recycled materials with dimensions that comply to AS/NZS 2890.1:2004. Suitable to install in factories, warehouses and car parks.

Features:

- Complies with AS/NZS 2890.1:2004.
- Economical and simple to install.
- Solid moulded construction.
- Recycled materials won't chip or corrode.
- Comes complete with fixings.

Material:	Recycled and natural rubber.
Finish:	Solid Black rubber with Hi-Vis Yellow panels.
Length:	1650mm.
Width:	155mm.
Height:	95mm.
Weight:	14kgs.
Fixings:	3 x 150mm Masonry anchors (gravel spikes optional).

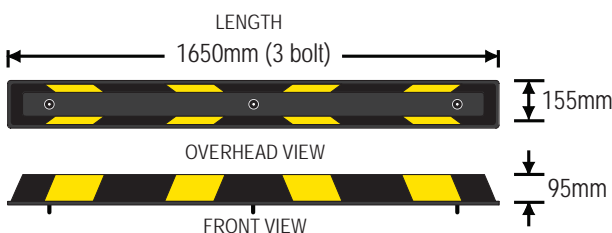

PART No.	DESCRIPTION
RWS1650	One piece rubber wheel stop – Black (fixings supplied)
SPIKES	Optional steel gravel spikes for fixing into loose surfaces – 300 x 12mm each



TRUCK STOP

Heavy duty wheel stops for use with trucks and mobile machinery in two sizes. Manufactured from heavy wall steel tube and hot dipped galvanised. Note: This product is designed to be industry specific and as such may not comply with the relevant standards for wheel stop design. Designed to be installed into concrete surfaces.

Features:

- Heavy steel construction with 6 point fixing.
- Available in 2 diameters and lengths.
- Hot dip galvanised for harsh environments.
- Suitable for truck or machinery parking areas.

Material:	Mild steel tube with 5mm wall.
Finish:	Hot dip galvanised.
Diameter:	90mm or 140mm.
Height:	100mm or 165mm.
Length:	1800mm or 2000mm.
Weight:	23kgs or 40kgs.
Fixings:	6 x M10 bolts (supplied).

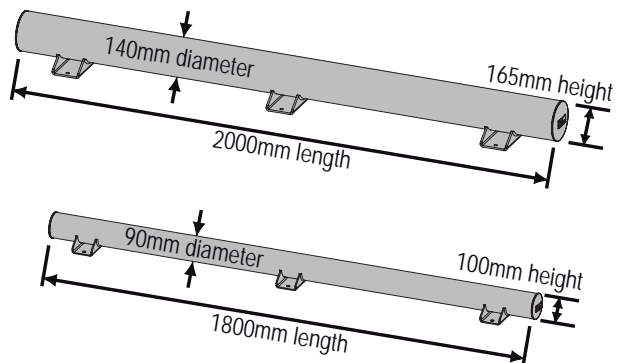

PART No.	DESCRIPTION
TS90-G	Heavy truck stop 90 x 5 x 1800mm – Galvanised
TS140-G	Heavy truck stop 140 x 5 x 2000mm – Galvanised