

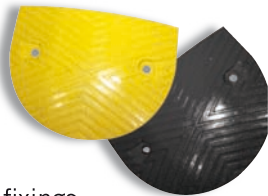

ROUND RUBBER HUMPS

Features:

- Full load bearing contact area with road surface.
- Convenient modular system can be configured to any length.
- All modules supplied with fixings.
- Concealed fixings remain accessible.
- Shock absorbent rubber is quiet and smooth.
- Rubber construction conforms to uneven surfaces.



Material:	Solid natural and recycled rubber.
Finish:	Black/Yellow moulded rubber sections.
Length:	500mm body modules. 250mm end caps.
Width:	350mm (body modules and end caps).
Height:	50mm.
Weight:	7kgs body module (each). 2kgs end caps (pair).
Fixings:	4 per body module. 2 per pair or end caps (supplied).

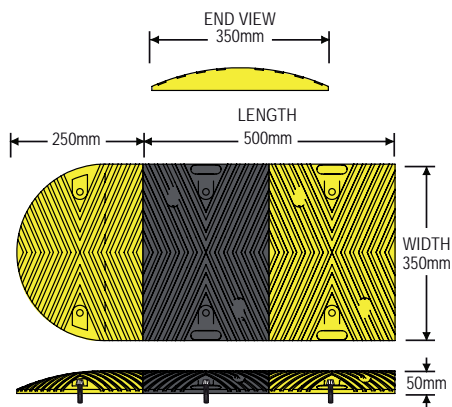

PART No.	DESCRIPTION
SMTC350BY	Round rubber hump body 350 x 500 x 50mm – Black/Yellow
SMTC350EB	Round rubber hump end cap 350 x 250 x 50mm – Black
SMTC350EY	Round rubber hump end cap 350 x 250 x 50mm – Yellow
BSHKIT	Complete speed hump sign kit



ROAD SPIKES One Way Access Spikes

Features:

- Extremely strong construction, 6mm top plate.
- Hi-Vis Lime Green with Orange spikes.
- Deters access from unauthorised direction.
- All teeth operate independently of each other.
- Low profile design ensures legal vehicle clearance.
- Soft approach due to low ramp angle.
- Comes complete with all fixings.
- Available in 1000 and 500mm lengths.
- Non-locking designed spikes.

Finish:	Powder coated Lime Green and Orange.
Top Skin:	6mm floor plate.
Length:	1000mm or 500mm.
Width:	380mm.
Height:	95mm teeth extended. 50mm teeth retracted.
Weight:	BRS500 – 13kgs (approx.) BRS1000 – 26kgs (approx.) BRSE – 5kgs per pair (approx.)
Fixings:	8 per metre (supplied). 4 per ½ metre (supplied).



PART No.	DESCRIPTION
BRS1000	Blade runner one way access spikes body – 1000mm
BRS500	Blade runner one way access spikes body – 500mm
BRSE	Blade runner end caps (pair)
BRSKIT	Blade runner warning sign kit



TRAFFIC CALMING HUMPS

Features:

- Full load bearing contact area with road surface.
- Modular system can be configured to any length.
- All modules supplied with fixings.
- Concealed fixings remain accessible.
- Highly shock absorbent rubber is both quiet and smooth in operation.
- Rubber construction conforms to uneven surfaces.
- Middle sections fitted with high visibility non-slip panels.

Material:	Solid natural and recycled rubber.
Finish:	Black moulded rubber, Yellow panels.
Length:	500mm body modules. 270mm end caps.
Width:	900mm (body modules and end caps).
Height:	50mm.
Weight:	20kgs body modules (each). 15.7kgs end caps (pair).
Fixings:	5 per body module. 6 per pair of end caps (supplied).

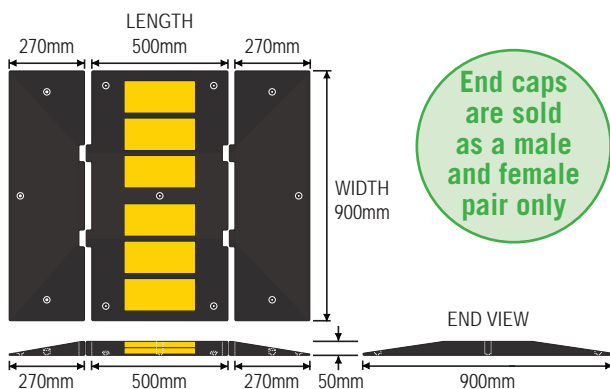

PART No.	DESCRIPTION
SMTc900	Traffic calming rubber hump middle 900 x 500mm
SMTc900E	Traffic calming rubber hump end cap (pair) 900 x 270mm



RUBBER SPEED CUSHION

Features:

- Embedded reflective material increases visibility and safety, day or night.
- All-weather easy maintenance: will not warp, chip, crack, crumble or corrode.
- Extremely durable: tough enough for heavy traffic.
- Flexible: conforms to road curvature and any asphalt or concrete surface.
- Resistant to extreme temperature variations, U.V., oils, moisture and damage.
- Available as a four or six panel kit.

Material:	Recycled rubber.
Finish:	Black with embedded reflective panels.
Length:	1000mm individual panels. 2000 or 3000mm assembled cushion.
Width:	900mm individual panels. 1800mm assembled cushion.
Height:	65mm.
Weight:	57kgs middle module. 40kgs corner module. 200 or 300kgs assembled (approx.)
Fixings:	Masonry anchors (supplied).

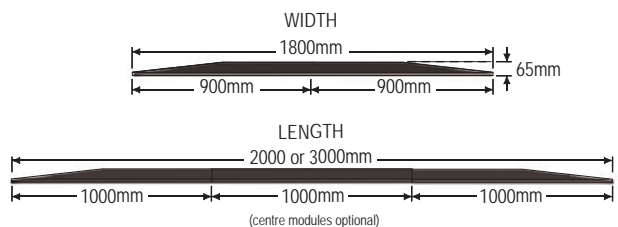

PART No.	DESCRIPTION
RSC-KIT4	Rubber speed cushion – 4-panel kit
RSC-KIT6	Rubber speed cushion – 6-panel kit
RSC-R	Rubber speed cushion – right end
RSC-M	Rubber speed cushion – middle
RSC-L	Rubber speed cushion – left end