



## RUBBER WHEEL STOP

An economical one piece rubber wheel stop with Hi-Vis Yellow panels. Manufactured from recycled materials with dimensions that comply to AS/NZS 2890.1:2004. Suitable to install in factories, warehouses and car parks.

### Features:

- Complies with AS/NZS 2890.1:2004.
- Economical and simple to install.
- Solid moulded construction.
- Recycled materials won't chip or corrode.
- Comes complete with fixings.

<b>Material:</b>	Recycled and natural rubber.
<b>Finish:</b>	Solid Black rubber with Hi-Vis Yellow panels.
<b>Length:</b>	1650mm.
<b>Width:</b>	155mm.
<b>Height:</b>	95mm.
<b>Weight:</b>	14kgs.
<b>Fixings:</b>	3 x 150mm Masonry anchors (gravel spikes optional).

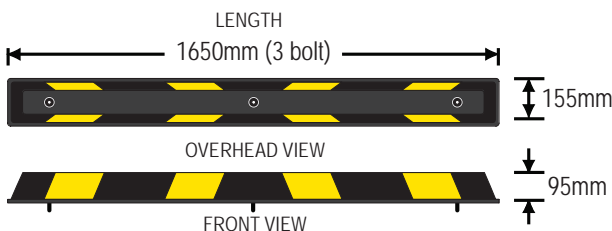

PART No.	DESCRIPTION
RWS1650	One piece rubber wheel stop – Black (fixings supplied)
SPIKES	Optional steel gravel spikes for fixing into loose surfaces – 300 x 12mm each



## TRUCK STOP

Heavy duty wheel stops for use with trucks and mobile machinery in two sizes. Manufactured from heavy wall steel tube and hot dipped galvanised. Note: This product is designed to be industry specific and as such may not comply with the relevant standards for wheel stop design. Designed to be installed into concrete surfaces.

### Features:

- Heavy steel construction with 6 point fixing.
- Available in 2 diameters and lengths.
- Hot dip galvanised for harsh environments.
- Suitable for truck or machinery parking areas.

<b>Material:</b>	Mild steel tube with 5mm wall.
<b>Finish:</b>	Hot dip galvanised.
<b>Diameter:</b>	90mm or 140mm.
<b>Height:</b>	100mm or 165mm.
<b>Length:</b>	1800mm or 2000mm.
<b>Weight:</b>	23kgs or 40kgs.
<b>Fixings:</b>	6 x M10 bolts (supplied).

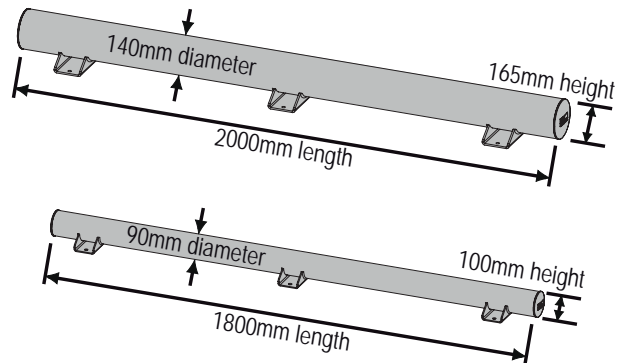

PART No.	DESCRIPTION
TS90-G	Heavy truck stop 90 x 5 x 1800mm – Galvanised
TS140-G	Heavy truck stop 140 x 5 x 2000mm – Galvanised